

Feature

SDL-5N3LPE-A

- High Luminous Output Bluish-Green LED Lamp
- Chip Technology – InGaN
- Standard 5mm (T-1 3/4) Water Clear Packages
- Viewing Angle **30** Degree (Reference)

Specification

Absolute Maximum Ratings

Item	Symbol	Absolute Maximum Rating	Unit
DC Forward Current	I_F	30	mA
Peak Pulsed Forward Current ※	I_{FP}	100	mA
Reverse Voltage	V_R	5	V
Power Dissipation	P_d	114	mW
Operating Temperature	T_{opr}	-30 ~ +85	°C
Storage Temperature	T_{stg}	-40 ~ +100	°C
Solder Dipping Temperature	T_{sld}	260°C for 5 sec	

※ I_{FP} = Pulse Width ≤ 10 ms, Duty Ratio $\leq 1/10$

Electrical / Optical Characteristics

$T_a = 25^\circ\text{C}$

Item	Symbol	Condition	Min	Typ	Max	Unit
Forward Voltage	V_F	$I_F=20\text{mA}$		3.1	3.6	V
Reverse Current	I_R	$V_R=5\text{V}$			50	μA
Luminous Intensity	I_V	$I_F=20\text{mA}$	7200	14000	21000	mcd
Dominant Wavelength	λ_d	$I_F=20\text{mA}$	495	505	510	nm
Peak Wavelength	λ_p	$I_F=20\text{mA}$		503		nm
Spectral Half Width	$\Delta \lambda_{1/2}$	$I_F=20\text{mA}$		30		nm



Electrostatic Sensitive Devices

Luminous Intensity Bin Table

IF=20mA

Rank name	Min (mcd)	Max (mcd)
Y	9300	12000
Z	12000	15700
ZA	15700	21000

※ Tolerance for each bin limit is $\pm 15\%$

Color Bin Table

IF=20mA

Rank name	Min (nm)	Max (nm)
2	500	505
3	505	510

※ Tolerance for each bin limit is $\pm 1\text{nm}$

Note

1. One delivery will include several color ranks and I_v ranks of products.
The quantity-ratio of the different rank is decided by Sander.
2. Bin Name typed on the Label: IV RANK + Color Rank.
For Example, **BIN Y2 Means IV: 9300~12000mcd and Color: 500nm~505nm**
3. Static Electricity or Surge Voltage damages the LEDs.
It is recommended to use a wrist band or Anti-Electrostatic glove when handling the LEDs.
4. Sander has the right to update the information without notice.
Please double confirm the Spec details before place an order.



Electrostatic Sensitive Devices

Outline Dimensions

Lamps with Standoffs

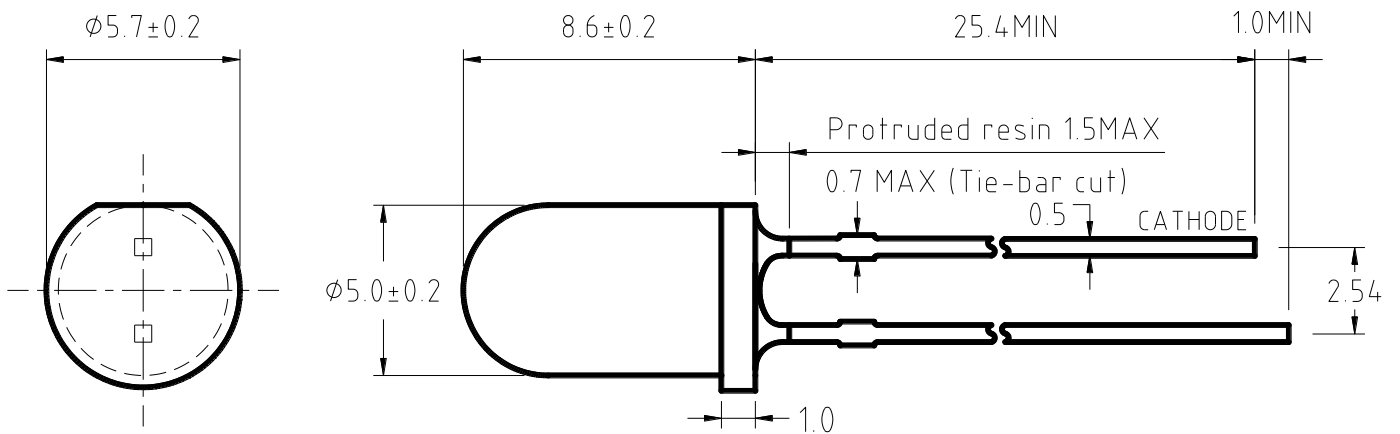

Item	Materials
Resin	Epoxy Resin
Lead Frame	Ag Plating on SPCC

Note.

1. All Dimensions are in Millimeters



Electrostatic Sensitive Devices

Electrical-Optical Characteristics

Forward Current vs. Forward Voltage

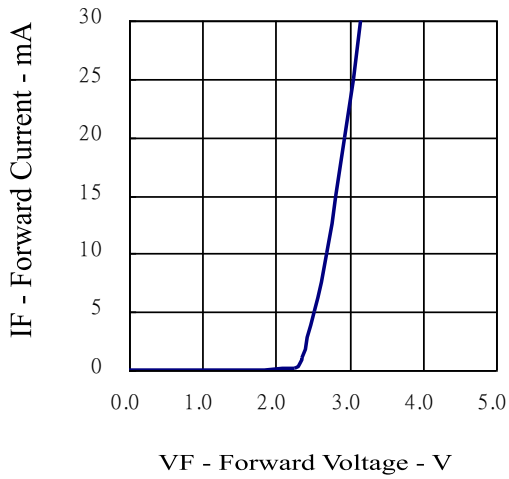

Relative Intensity vs. Forward Current

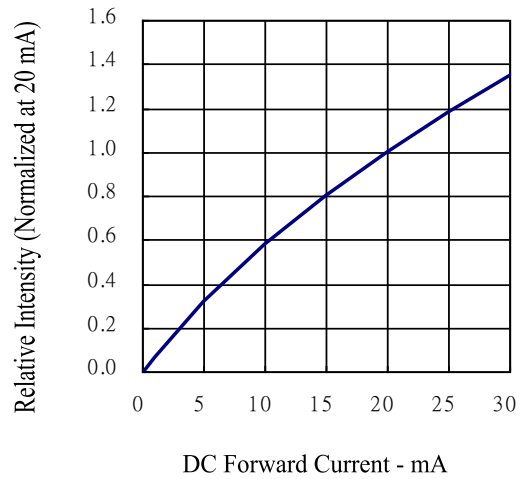

Forward Current vs. Ambient Temperature

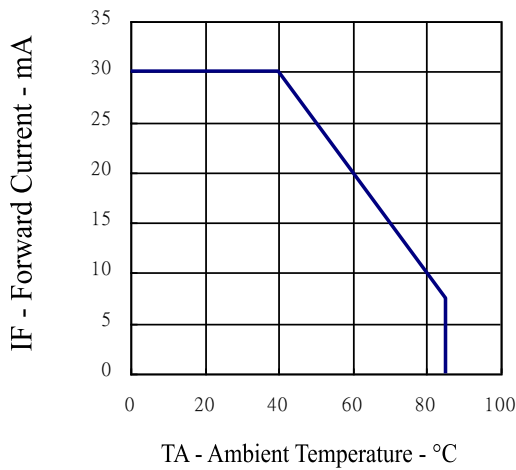

Relative Intensity vs. Wavelength

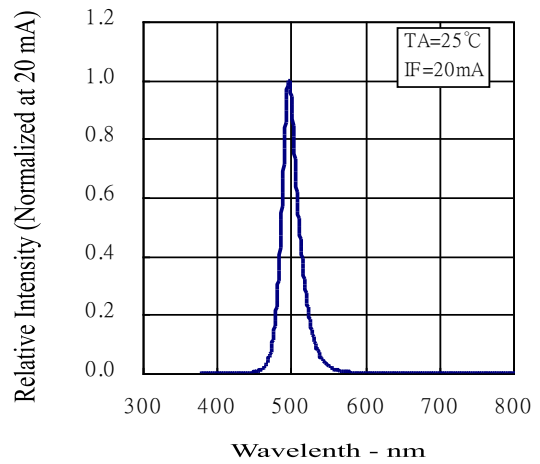

Soldering Conditions - Lamp Type LED

- Solder the LED no closer than 3mm from the base of the epoxy bulb. Soldering beyond the base of the tie bar is recommended
- Recommended soldering conditions

Dip Soldering	
Pre-Heat	100°C Max.
Pre-Heat Time	60 sec. Max.
Solder Bath Temperature	260°C Max.
Dipping Time	5 sec. Max.
Dipping Position	No lower than 3mm from the base of the epoxy bulb.

Hand Soldering		
	3Ø Series	Others (Including Lead-Free Solder)
Temperature	300°C Max.	350°C Max.
Soldering time	3 sec. Max.	3 sec. Max.
Position	No closer than 3mm from the base of the epoxy bulb.	No closer than 3mm from the base of the epoxy bulb.

- Do not apply any stress to the lead, particularly when heated
- The LEDs must not be repositioned after soldering
- After soldering the LEDs, the epoxy bulb should be protected from mechanical shock or vibration until the LEDs return to room temperature.
- Direct soldering onto a PC board should be avoided. Mechanical stress to the resin may be caused by the PC board warping or from the clinching and cutting of the leadframes. When it is absolutely necessary, the LEDs may be mounted in this fashion, but, the User will assume responsibility for any problems. Direct soldering should only be done after testing has confirmed that no damage, such as wire bond failure or resin deterioration, will occur. Sander's LEDs should not be soldered directly to double sided PC boards because the heat will deteriorate the epoxy resin.
- When it is necessary to clamp the LEDs to prevent soldering failure, it is important to minimize the mechanical stress on the LEDs.
- Cut the LED leadframes at room temperature. Cutting the leadframes at high temperatures may cause LED failure.